

# Defender Kitchen Hood Fire Extinguishing System

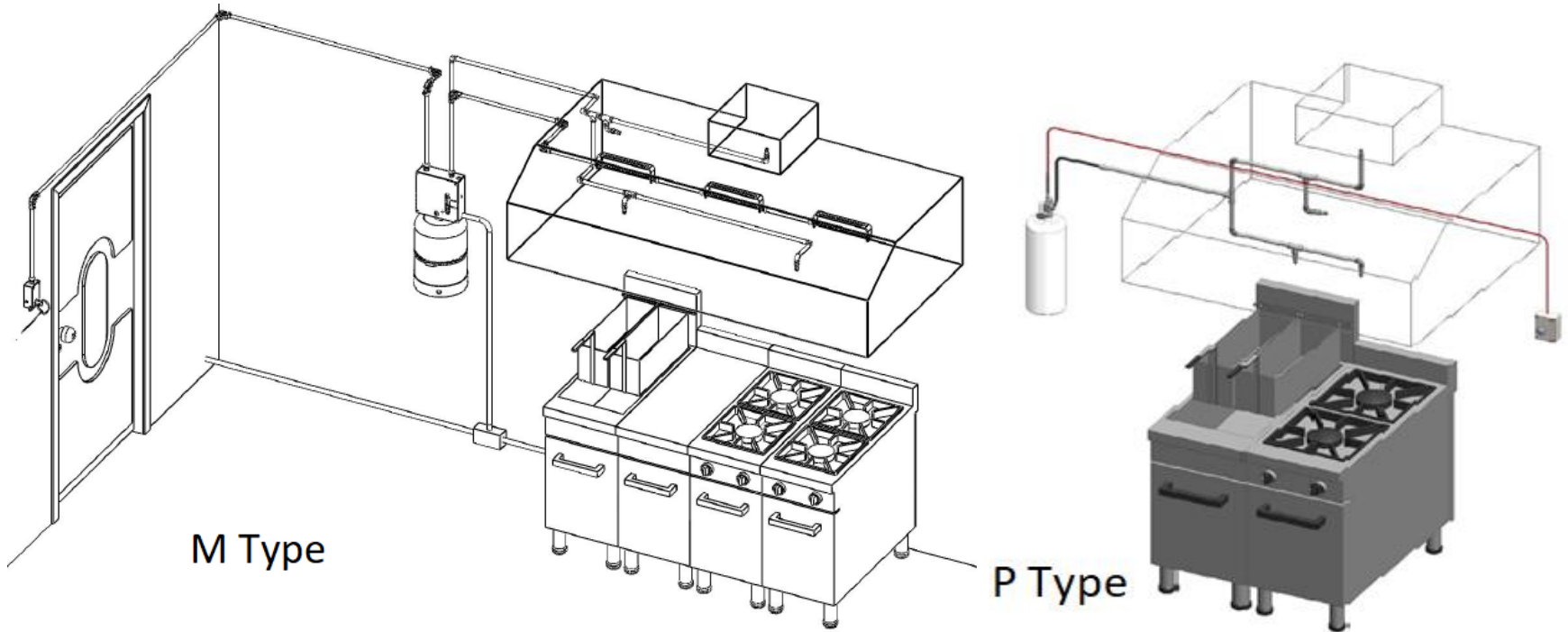

## Kitchen Duct, Hood and Appliance Fire Extinguishing Systems

- ▶ The duct, hood and appliance have high fire risk with heat, oil and air in kitchen
- ▶ The cook or appliance faults cause high fire risk
- ▶ The dirty hood and duct cause high fire risk
- ▶ The duct, Hood and Appliance fires spread rapidly in the building through ducts
- ▶ The duct, hood and appliances fires are difficult to extinguish with 360C heat from oil



## Kitchen Duct, Hood and Appliance Fire Extinguishing Systems

- ▶ The most of local regulations stipulate kitchen duct hood and appliance extinguishing systems before building opening
- ▶ The most of consultants and advisors stipulate kitchen duct hood and appliance extinguishing systems during Project base
- ▶ There is huge demand for preferable and competitive kitchen duct hood and appliance fire extinguishing system World wide
- ▶ Defender is preferred and competitive for installer and end users as kitchen duct hood and appliance fire extinguishing system



## Defender is Preferable

- ▶ Defender is manufactured and supported by FINDER company.
  - ▶ 24 years experience
  - ▶ 7/24 sales and technical support
  - ▶ Fast Delivery
  - ▶ Technical Training
  - ▶ Trained and Authorized Installers
  - ▶ Exclusive Dealers
  - ▶ Regular Installation Inspection
  - ▶ Regular Customer Satisfaction Control
  - ▶ Marketing Support
    - ▶ Brand Awareness
    - ▶ Direct Mailing
    - ▶ E marketing
    - ▶ Exhibition participation
    - ▶ Marketing Documents

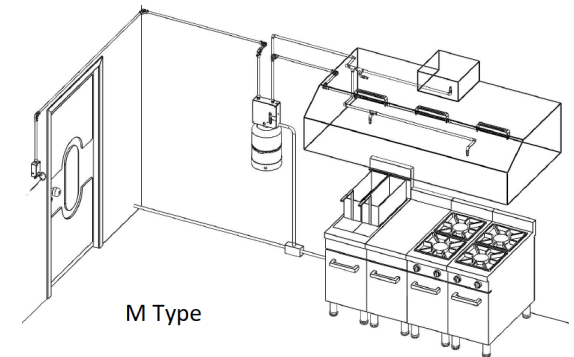
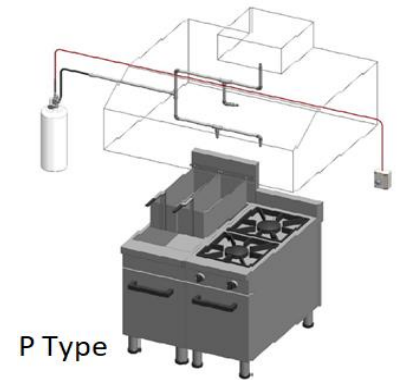

## Defender is Preferable

- ▶ Defender is easy to install, use and maintain.
- ▶ Defender M mechanical system is suitable for difficult applications
- ▶ Defender P pressurized system is suitable for fast detection and cost effective applications
- ▶ Defender meets customer different sized applications requirements

4 nozzle systems  
8 nozzle systems  
12 nozzle systems  
16 nozzle systems  
18 nozzle systems

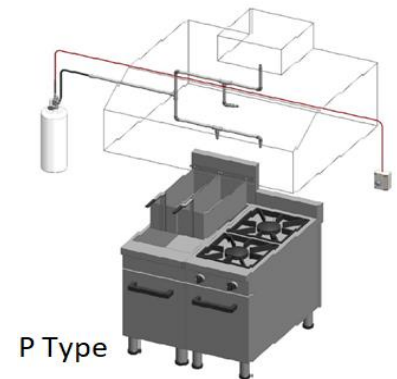
The logo for Finder, featuring a magnifying glass icon followed by the word 'Finder' in a bold, sans-serif font, with the tagline 'Reliable Technology' underneath.

P Type

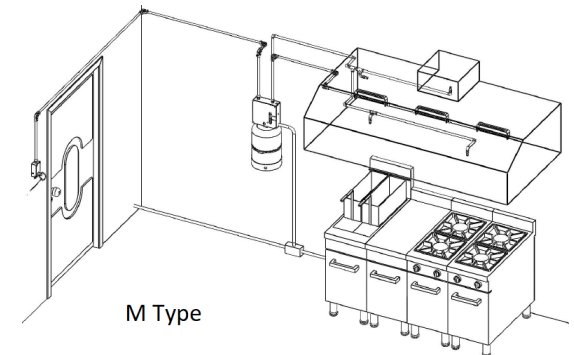

M Type

# Defender is Preferable

- ▶ Defender performance is tested and approved by LPCB

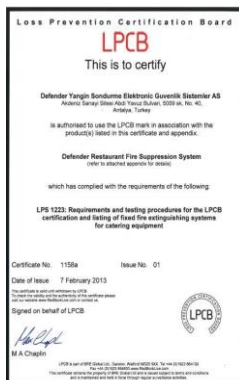
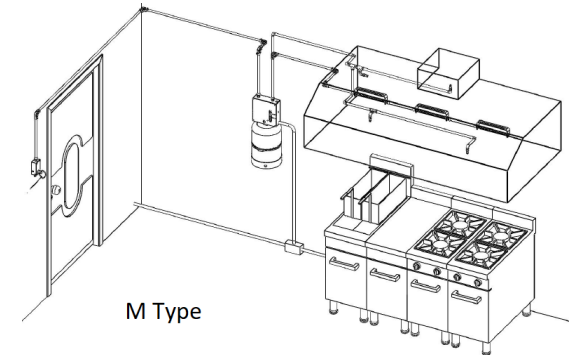
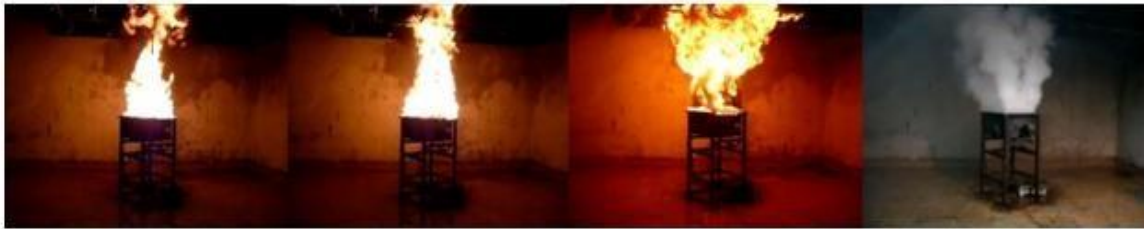
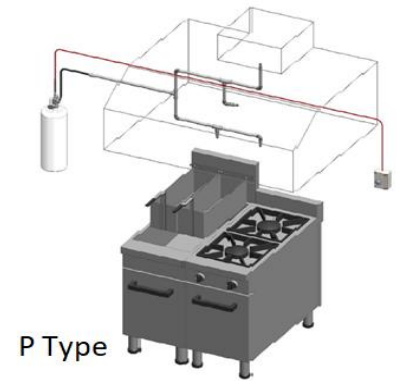

## Defender is Competitive

- ▶ Defender nozzles coverage are wider than the others. The less pipe works, labor cost and cylinder capacity are needed
- ▶ Defender cylinders are pressurized. The maintenance and charging are cost effective
- ▶ Defender control head operates both manual and automatic. The additional manual release is not necessary.
- ▶ Defender P series with pressurized piping system is cost effective to meet customer expectations

### WIDE NOZZLE COVERAGE

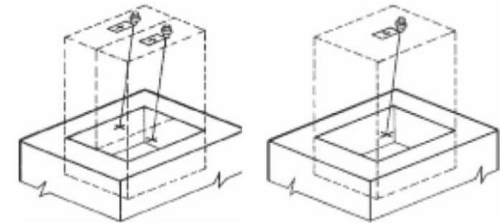

OTHERS

DEFENDER

